

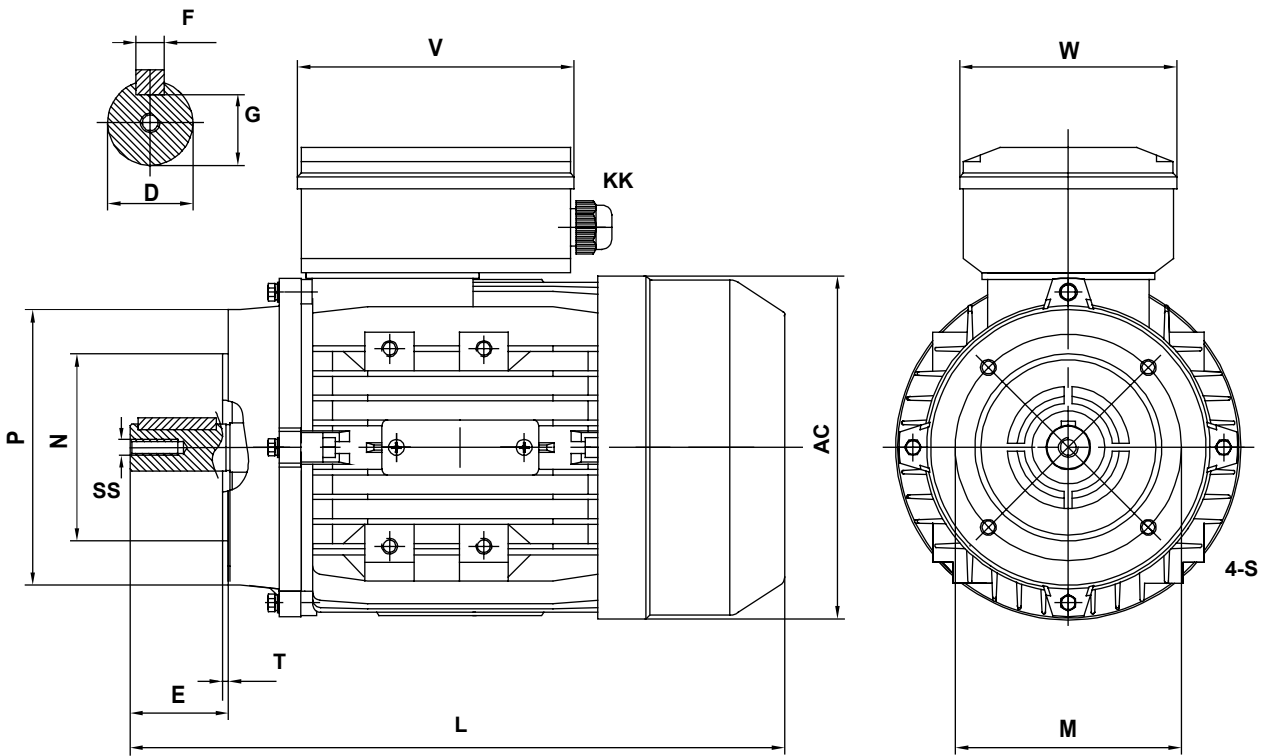

DIMENSIONI D'INGOMBRO B14

OVERALL DIMENSIONS B14



B14 - FACE MOUNTING

FRAME	D	E	F	G	M	N	P	T	S	AC	SS	L	V	W	KK
56	Φ9	20	3	7.2	Φ65	Φ50	Φ80	2.5	M5	110	M3	195	69	69	1-M16 x 1.5
63	Φ11	23	4	8.5	Φ75	Φ60	Φ90	2.5	M5	120	M4	215	94	94	1-M16 x 1.5
71	Φ14	30	5	11	Φ85	Φ70	Φ105	2.5	M6	145	M5	240	94	94	1-M20 x 1.5
80	Φ19	40	6	15.5	Φ100	Φ80	Φ120	3.0	M6	165	M6	290	105	105	1-M20 x 1.5
90S	Φ24	50	8	20	Φ115	Φ95	Φ140	3.0	M8	185	M8	310	105	105	1-M20 x 1.5
90L	Φ24	50	8	20	Φ115	Φ95	Φ140	3.0	M8	185	M8	335	105	105	1-M20 x 1.5
100L	Φ28	60	8	24	Φ130	Φ110	Φ160	3.5	M8	205	M10	368	105	105	1-M20 x 1.5
100L2**	Φ28	60	8	24	Φ130	Φ110	Φ160	3.5	M8	205	M10	386	112	112	1-M20 x 1.5
112M	Φ28	60	8	24	Φ130	Φ110	Φ160	3.5	M8	230	M10	395	112	112	2-M25 x 1.5
132S	Φ38	80	10	33	Φ165	Φ130	Φ200	3.5	M10	270	M12	436	112	112	2-M25 x 1.5
132M	Φ38	80	10	33	Φ165	Φ130	Φ200	3.5	M10	270	M12	474	112	112	2-M25 x 1.5

* ALL DIMENSIONS ARE IN MM.

**THIS FRAME HAS THE BIGGER OUTPUT IN LOWER FRAME SIZE.